

Cooling Solution for Orin NX/Nano



Heatsink / Heatspreader / Leaf spring

Overview

The Orin NX/Nano leaf spring kits for secure mounting of cooling solutions. This ensures optimal thermal interface while minimizing the risk of damaging the module.

Implementation guidelines

- Refer to Nvidia Orin Nano/NX Thermal Design Guide for thermal dissipation requirements
- Recommended material for heatsink is aluminum or copper
- Use intermediate heat transfer compound (paste or pad), do not screw the module directly to heatsink/heat spreader or case
- When using heatspreader use thermal pad >0.5mm between heatspreader and enclosure to ensure thermal conductivity
- Do not cover the module envelope
- Use <0.15Nm for Tx6 screws
- Handle module with care during assembly (ESD)
- Ensure correct orientation of the spring. The leaf spring should only contact the module in the middle
- SO-DIMM connector spacers must be used to reduce stress on the PCB

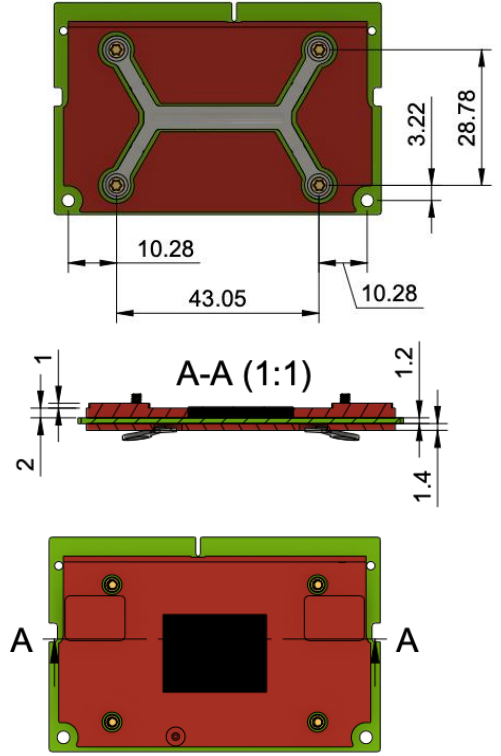
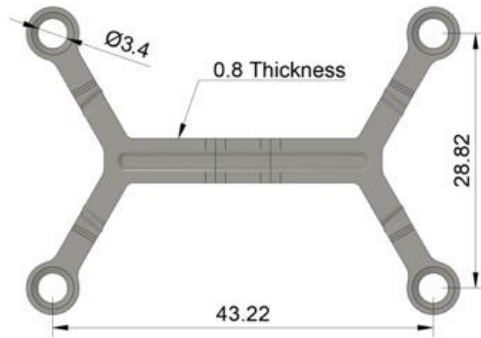

Jetson compute module with leaf spring

RED: module envelope, keep out zone for component clearance

BLUE: Processor die

GREEN: PCB + underside

The envelope for thermal solution 3D model is available in the Nvidia developer download area

SKU	Kit	Includes
70696	Leaf spring kit	<ul style="list-style-type: none"> Leaf spring 4x screws (Tx6)
70798-OK	Cooling kit	<ul style="list-style-type: none"> Heatsink (70812) with integrated fan Leaf spring 4x screws (Tx6)
70810-OK	Cooling kit Industrial	<ul style="list-style-type: none"> Industrial heatsink (70812-C) Leaf spring 4x screws (Tx6)
70606	Heatspreader	<ul style="list-style-type: none"> Heatspreader 4.15mm
70606-1	Heatspreader	<ul style="list-style-type: none"> Heatspreader 5.15mm
70606-2	Heatspreader	<ul style="list-style-type: none"> Heatspreader 6.65mm
70606-3	Heatspreader	<ul style="list-style-type: none"> Heatspreader 3.15mm
70606-4	Heatspreader	<ul style="list-style-type: none"> Heatspreader 7.25mm
70812	Heatsink	<ul style="list-style-type: none"> Heatsink with integrated fan
70812-C	Heatsink Industrial	<ul style="list-style-type: none"> Industrial heatsink
70810-CP	Super mode copper heatsink	<ul style="list-style-type: none"> Copper heatsink FAN Leaf spring 4x screws (Tx6)
70812-P	Passive heatsink	<ul style="list-style-type: none"> Passive heatsink



Specifications subject to change without notice. All trademarks are property of their respective holder.

Cooling Solution for Orin NX/Nano

Active cooling solution comparison

Orin NX	Heatsink industrial	Fan integrated heatsink	Super mode copper heatsink 10mm FAN	Super mode copper heatsink 15mm FAN
Heat resistance	1.7K/W	1.9K/W	1.2K/W	1.05K/W
Noise dBA at 100cm	36	37	38	41
Weight				
Outer dimensions (mm)	66x40x20.6	57.8x39x18	66x44.2x27	66x44.2x32
Nominal power draw	0.4W	0.65W	1.4W	1.5W
Cooling fin material	Al	Al	Cu	Cu
Max recorded power dissipation at 45° ambient	25W	25W	40W	40W
CFM	5.6	5	3.35	3.67
RPM	5500	6000	6000	6000
SKU	70812-C	70812	70810-CP	Available on request

Cooling kits

Cooling kit (70798-OK)



Fan integrated heatsink (70812) 23mm cable length



Cooling kit industrial (70810-OK)



Heatsink industrial (70812-C) 101mm cable length



Leaf spring kit (70696)



Passive heatsink (70812-P)



Cooling Solutions

Cooling Solutions

Cooling Solution for Orin NX/Nano

Super mode copper heatsink kit (70810-CP)

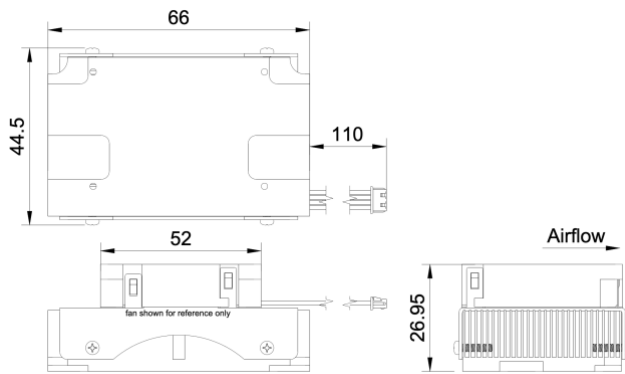

Heatspreader

Heatspreader 4.15mm (70606)

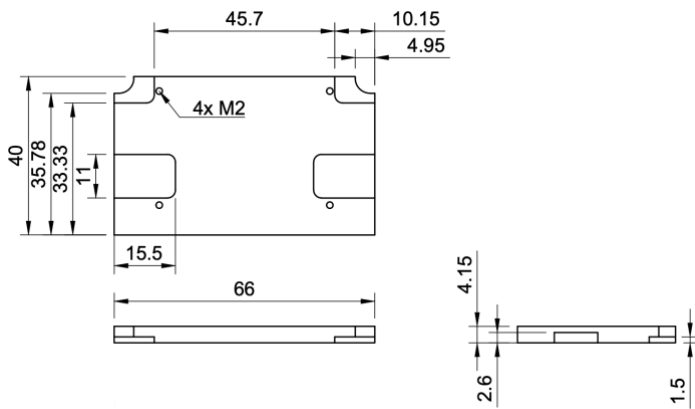

Heatspreader 5.15mm (70606-1)

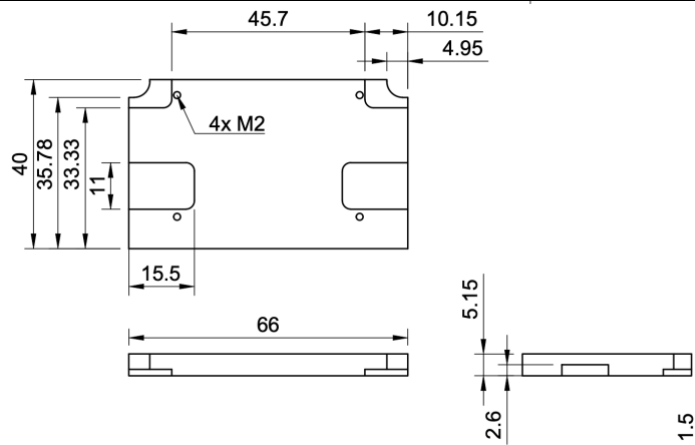

Heatspreader 6.65mm (70606-2)

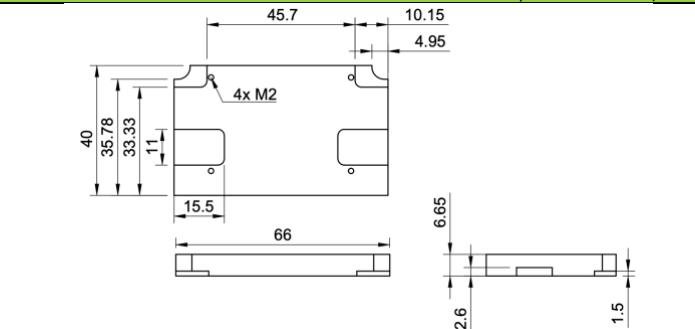

Cooling Solutions

Cooling Solution for Orin NX/Nano

